

## EF COUPLER

04 Update - 06/2023

### TECHNICAL DATA

Article No	109 117 2160 0710
d (mm)	710
D (mm)	882
Z (mm)	475
m (mm)	
Weight (Kg)	72,45
Box Quantity (pcs)	1
Box Dimension (cm)	

### INJECTION MOULDED

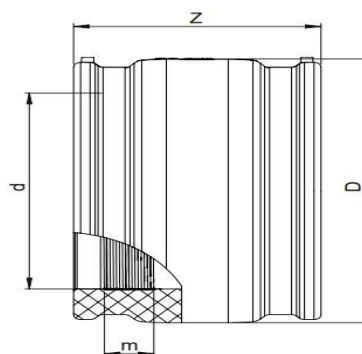

### IDENTIFICATION OF PRODUCT

D(mm)	710
SDR	11
RAW MATERIAL	PE 100
PRESSURE CLASS	16 Bar Water 10 Bar Gas
TRADEMARK	NTG
EXECUTION	Injection Moulded
STANDARD	EN 12201-3 EN 1555-3 AS / NZS 4129
SPECIFICATION	Suitable for SDR11....13,6 pipe 4 mm pin connectors Bifilar welding zone

### EF SPECIFICATION

WELDING VOLTAGE	40 V
RESISTANCE	0,510 Ω
WELDING TIME	2160 Sec.
COOLING TIME	60 Min.
WINDING TYPE	Bifilar
WELDING BARCODE	

Tolerance on diameters and thickness according to the standards. The other dimensions are specialized. Tolerance  $\pm 5\%$ . NTG PLASTIK reserves all the right to change any information without giving prior notice. The production, distribution and utilization of this document without explicit authorization is prohibited.